

# **Boardwalk Construction Guidelines**



**Acton Land Stewardship Committee  
Acton, Massachusetts**

NOTICE TO AGENCIES OUTSIDE THE ACTON LAND STEWARDSHIP COMMITTEE

THE *BOARDWALK CONSTRUCTION GUIDELINES* DOES NOT CONSTITUTE A SPECIFICATION AND IS INTENDED SOLELY AS A GUIDELINE. IT SHOULD NOT BE USED IN ANY MANNER WHICH REPRESENTS IT AS BEING A STANDARD OR POLICY OF THE ACTON LAND STEWARDSHIP COMMITTEE.

## **Boardwalk Construction Guidelines**

Acton Land Stewardship Committee  
Bob Guba – Construction Coordinator

The Land Stewardship Committee developed these guidelines for boardwalk construction after it was formed in 1996 to manage the conservation lands of the town of Acton, Massachusetts. Analysis of earlier constructed boardwalks led to corrective construction procedures that are presented here to assure the following qualities: level and stable deck surface, strength, ease of disassembly and/or repair, non-polluting, extended life, and less susceptibility to vandalism.

**Site Survey** – The first step is a careful survey of the site where a boardwalk is required, as this will govern its design, materials, and cost. Place stakes along the centerline of the trail in the wetland where the boardwalk is to be located at stringer length intervals, typically 8 feet when using 4"x4"s, 9 feet for 2"x6"s, or 10 feet for 4"x6"s or 2"x8"s. The first and last stakes are placed at elevated points at the edge of the wetland slightly above typical high water level. If there are no natural barriers such as large trees and rocks to force the boardwalk to meander then slight turns every 30 to 40 feet should be incorporated into the design for an esthetic experience.

A string is secured to the first stake at ground level and continued to the following stakes using a string level. The boardwalk sill height above ground is now measured at each stake (see Figure 1). This assures the step-up at the boardwalk ends of no greater than a plank thickness.

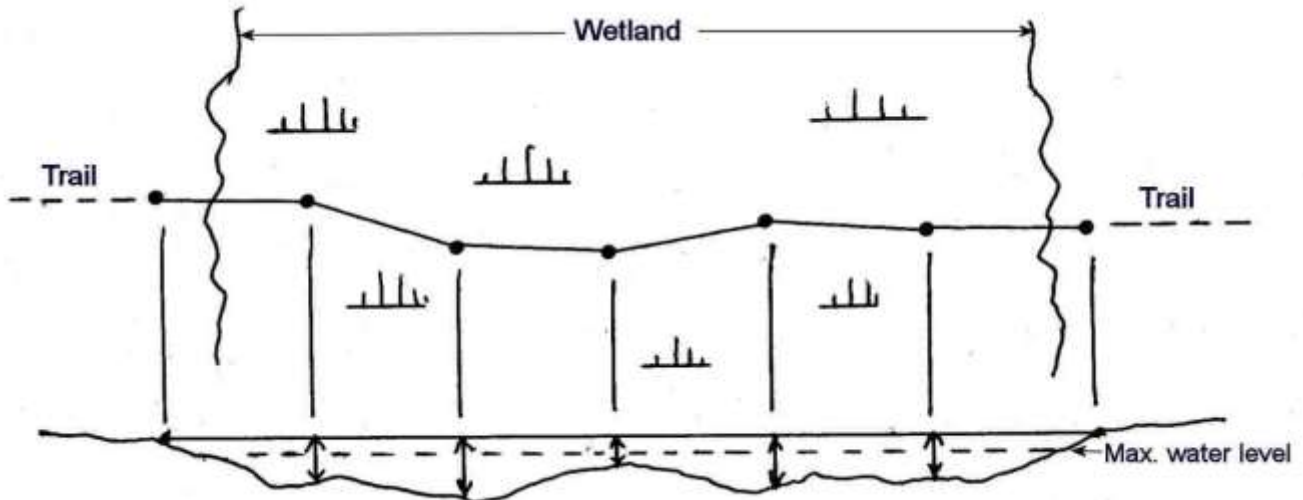

Figure 1 – Determining sill height and placement

**Boardwalk Support** – The boardwalk stringers are supported by laterally placed sills or steel pipe depending on wetland water depth. Material selection for the sills is an important phase of the boardwalk project. Earlier boardwalks relied on very heavy, polluting sections of utility poles or railroad ties for sills. Three sill materials that won't harm the environment are ACQ (Alkaline-Copper-Quaternary) pressure treated lumber, FRP (Fiberglass Reinforced Plastic) lumber, and double-wall corrugated plastic pipe.

For locales where maximum water depth doesn't exceed 6" inches, ground contact, pressure treated lumber can be used. For locales where maximum water depth

doesn't exceed 18 inches and the soil is fairly firm sills made with double-wall, annular ring, polyethylene pipe having the qualities of light weight and high strength is recommended. Plastic pipe diameters for boardwalk use range from 4" to 15". For stringer support in those areas where the soil is very soft and the water depth can exceed 18 inches use steel pipe with an attached dock fitting and auger that is rotated through the soft soil and peat to be securely embedded into the clay or gravel sub-soil. Figure 2 illustrates these methods.

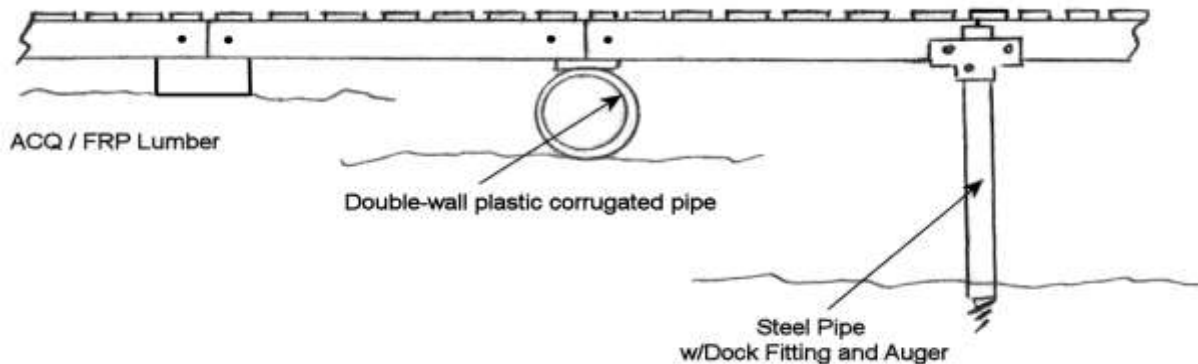

Figure 2 – Boardwalk support types

**Sill Fabrication** - Since most boardwalk locations are remote it helps to fabricate the sill assembly offsite where power tools are readily available. Lumber sills of 2"x6", 4"x6", or 6"x6" stock and plastic pipe sills use a bent Simpson "T" strap (Figure 3) to secure the stringers to the sills. Plastic pipe sills also require a stringer support pad (Figure 4) to provide a flat support surface on the pipe.

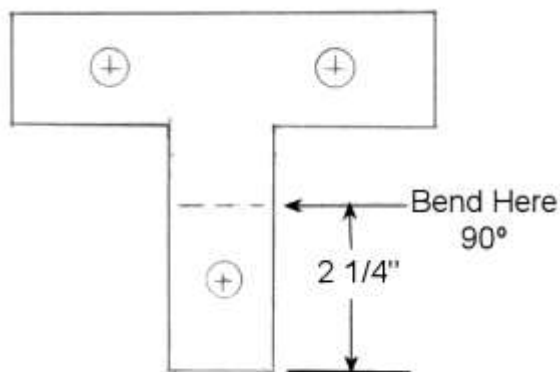

Figure 3 – Simpson T-Strap Tie

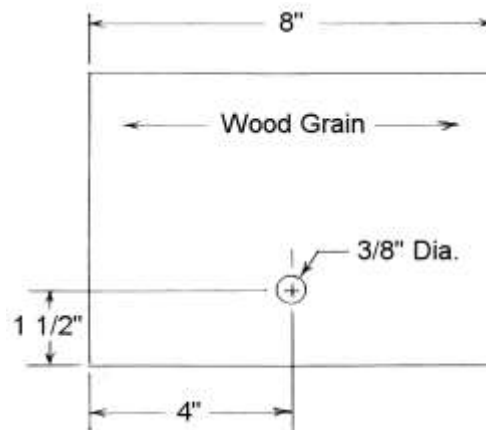

Figure 4 – Stringer Support Pad  
2"x6" ACQ Pressure Treated

**Lumber Sills** - Experience has shown that nailing the end of the stringer to the sills, either by nail toeing or driving spikes vertically through the stringer, stresses the wood and may cause a cracked stringer at the time of assembly or later from the stress of use and environmental effects due to the rigidity of the attachment. Stringers bolted to a metal bracket provide a more flexible attachment for stringer deflection. Figure 5 shows an end view of the attachment of the boardwalk stringers to the lumber sill.

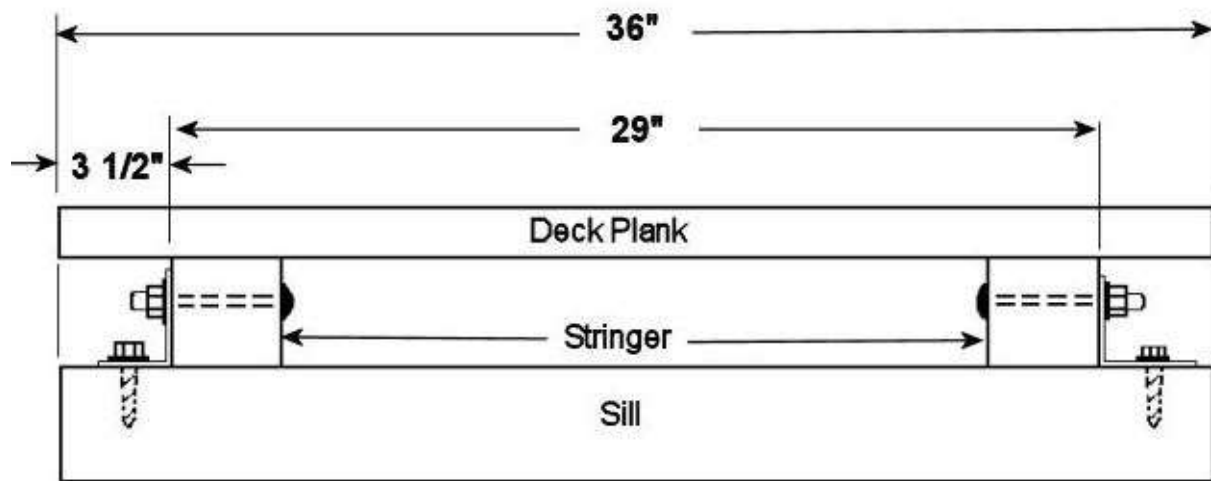

Figure 5 – ACQ Lumber Sill Assembly Detail

**Plastic Pipe Sills** – Figure 6 is an assembly drawing showing plastic pipe with an end view of stringer pads, brackets/hardware, stringer options and decking.

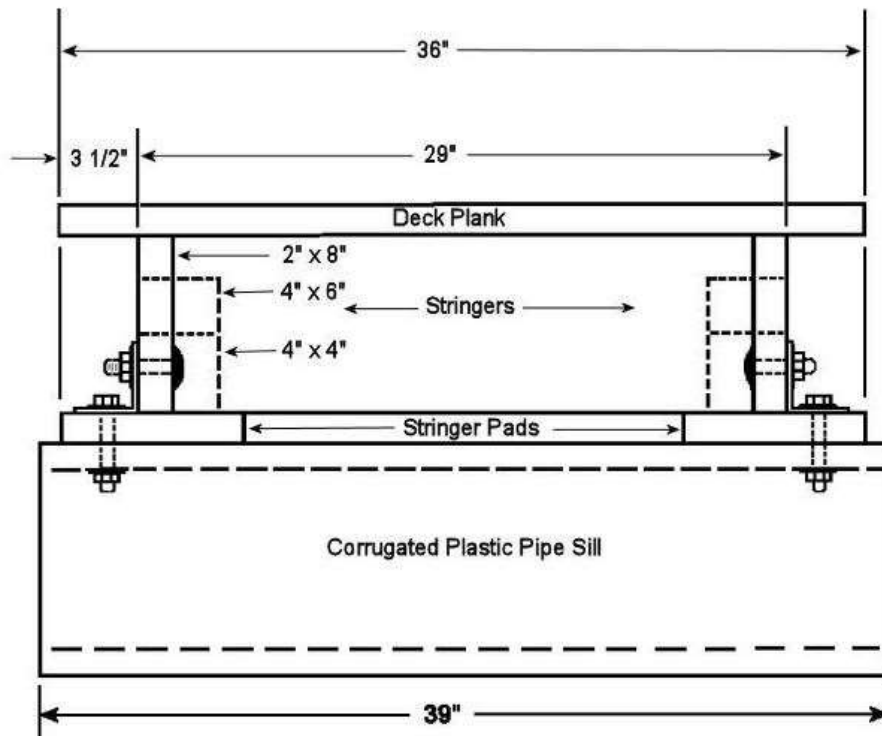

Figure 6 – Corrugated Plastic Pipe Sill Assembly Detail

**Steel Pipes** –An auger is permanently attached to 2” galvanized steel pipe that is rotated into the firm sub-soil with a pipe wrench. A dock fitting is then attached to support the stringer. This assembly is shown in Figure 7.



Figure 7 – Pipe with auger and dock fitting attached.

**Frame Stringers** – Frame stringers are used to obtain more deck height where considerable water depth can be expected. Another reason is to minimize the number of costly pipe and dock fittings by increasing the stringer span length. Figure 8 depicts the construction of a frame stringer using 2” lumber. This design can be assembled off site with three deck planks attached for strength in transport.

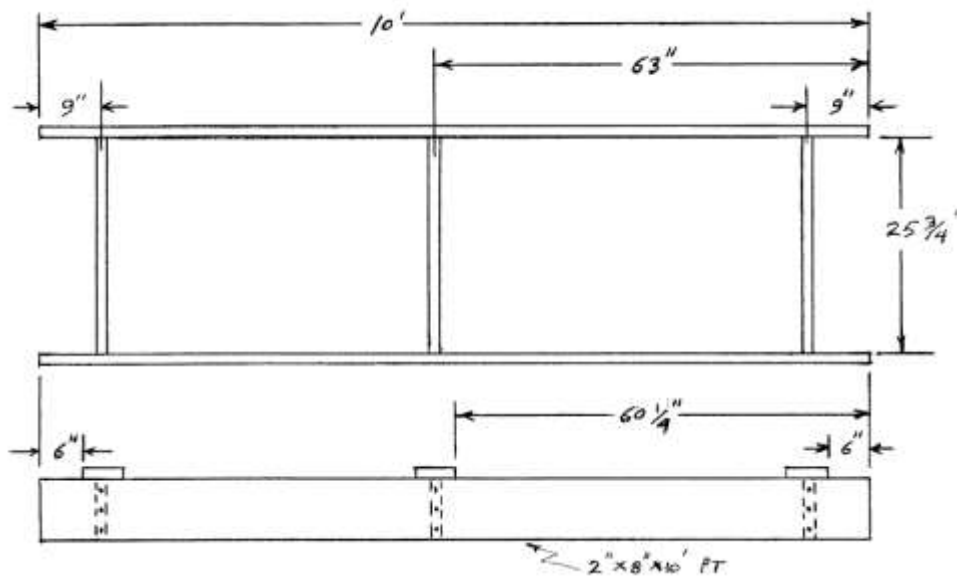

Figure 8 - Stringer Frame

**Sill Placement** – After the first sill is in place and level then the stringers can be placed across the span to the second sill and with the use of a carpenter level determine if the second sill has to be dug in more or shimmed up. Shimming is accomplished with an assortment of spacers made from 5/4" or 2" PT boards as depicted in Figure 4 that are placed between the "T" straps and the sill. Once the second sill is in place and leveled then the stringers can be bolted to the "T" straps. The use of bolts to secure the joint not only strengthens it but also facilitates removal of the boardwalk sections if damaged or needing relocation. Maintain a 3/8" gap between stringers at the junction point to allow for vertical flexing in case the ground is (or becomes) spongy. This process is repeated until the last sill is reached. If the wet area experiences high flooding, particularly near brooks, anchor the sills by using re-bar driven at an angle through the sills to prevent the boardwalk from shifting off its footprint. When using steel pipe for stringer support the path of the boardwalk must be probed at stringer-length intervals through the soft soil to the firm sub-soil with a thin, firm rod such as fiberglass wands or 3/8" dia. re-bar. This measurement is needed to calculate the required pipe lengths to support the boardwalk.

**Decking** – Planks for decking are 2"x 6"x3' PT boards Decking is screwed for ease of replacement at a typical spacing of 7/16". Due to slight plank width, using pairs of 3/8", 7/16", or 1/2" thick wood gauges for plank spacing along with a 3 1/2" gauge for plank overhang from the stringer are helpful when screwing the planks to the stringers.

Note: \* "A plank used for a deck often contains heartwood and sapwood. If the plank is placed with the heartwood face up, alternating moisture and drying—and the effects of freezing and thawing—will cause knots and some of the annual rings in the wood to lift. To reduce tripping hazards and future maintenance, deck plank should be placed "green side up" (the heart side face down and the bark side face up." See Figure 9).

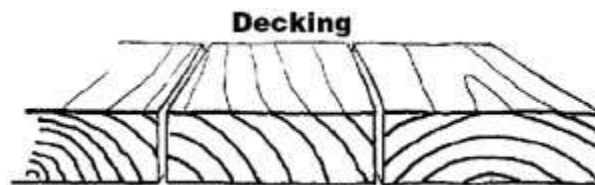

Figure 9—Place decking with the growth rings facing down to help prevent cupping. Cupping causes the wood to decay faster and creates a tripping hazard.

\*This procedure and diagram was obtained from the US Forest Service "Wetland Trail Design & Construction" 2007 Edition, Steinholtz & Vachowski.

Figure 10 illustrates two methods for decking at bends in the boardwalk. Fanning the planks as shown in 10(a) is useful for shallow bends while sharper bends use tapered planks cut as shown in 10(b) with equal spacing. The detail for cutting these tapered planks is shown in Figure 10(c).

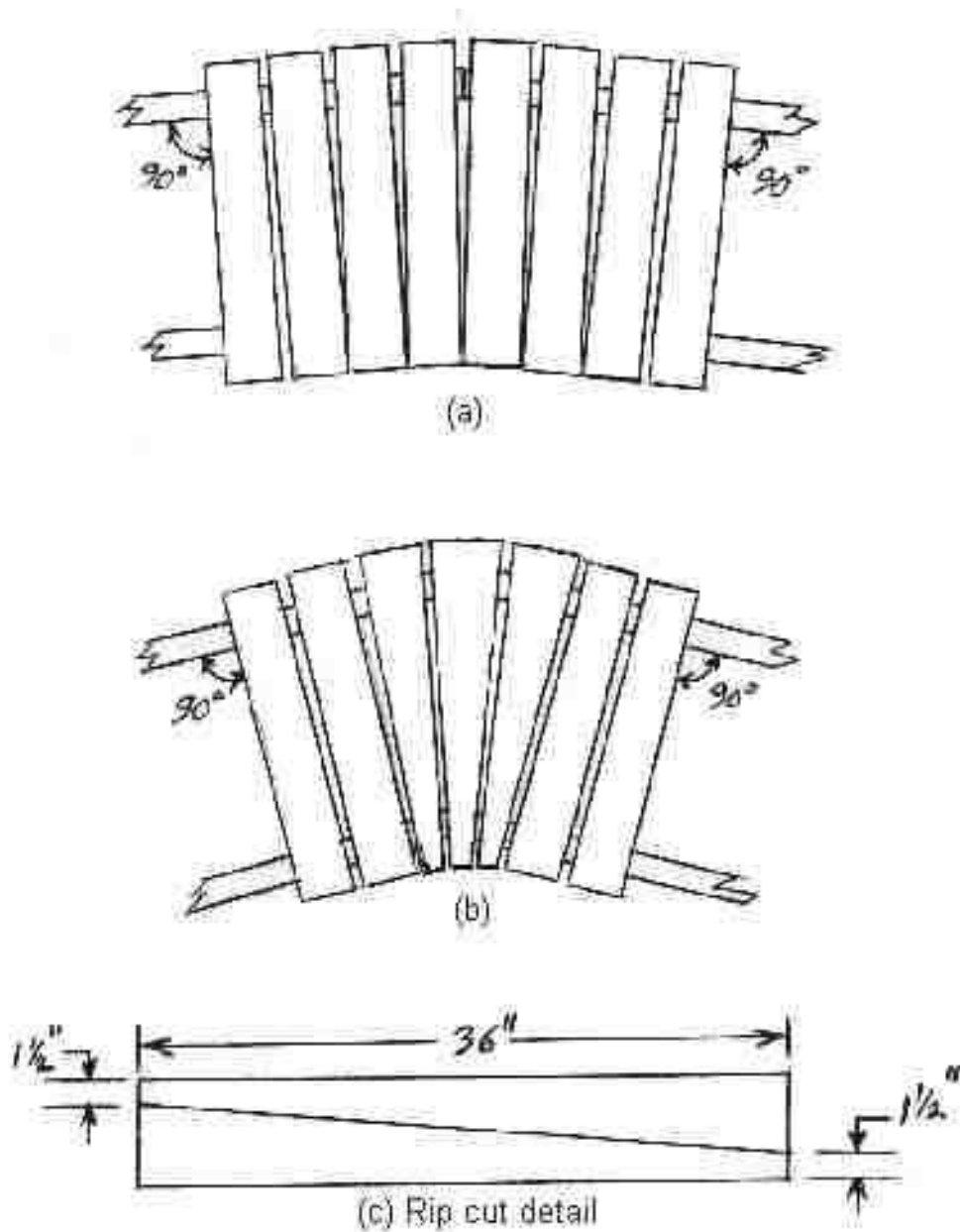

Figure 10 – Decking Detail at Bends



## Materials List

### **Sills**

2"x6", 4"x6" or 6"x6" #2 ground contact, ACQ pressure treated southern pine.

Polyethylene, dual wall, corrugated pipe [Advanced Drainage Systems](#)  
N-12 Plain End Pipe

### **Stringers**

4"x4", 4"x6", 2"x6", 2"x8", 2"x10" #1 ACQ pressure treated southern pine.

### **Planks**

2"x6" #1 Ground contact, ACQ, pressure treated southern pine.

### **Hardware**

Simpson Strong-Tie [T Strap](#) Model 66T

Dock hardware: [RDS](#) P.O. Box 298 West Franklin, NH 03235 1-800-934-1943  
[info@rdsdockhardware.com](mailto:info@rdsdockhardware.com)



2" galvanized steel pipe – schedule 40 \*  
3/8" lag screws, hot dipped galvanized \*  
3/8"-16 carriage bolts, hot dipped galvanized \*\*  
3/8"-16 hex head bolts, hot dipped galvanized \*\*  
3/8"-16 hex nuts, hot dipped galvanized  
3/8" flat washers, hot dipped galvanized  
3" x 9 - exterior screws, T-25 star drive-Type 17 point

\* length TBD

\*\* bolt threads must extend 1" minimum beyond bearing surface.